

SPRIZ

The VENIX logo features the brand name in a bold, white, sans-serif font. A stylized white flame or leaf-like shape is positioned above the letter 'V'.

**HIGH-SPEED
CONVECTION OVEN
FOR QUICK SERVICE**





SPRIZ

HIGH SPEED CONVECTION OVEN: A NEW SOLUTION FOR HEATING, REGENERATING AND DEFROSTING PRODUCTS

Today, there is a need for fast, easy-to-use, versatile, and affordable products. Venix understands this well and has created a new professional oven which uses air-impingement and forced ventilation technology, which shorten up many preparations into very quick.

SPRIZ is the perfect solution for regenerating pre-cooked products such as frozen pizzas, or preparing crunchy sandwiches or for heating any kind of snack.





IDEAL APPLICATION PLUG & PLAY

- Bars / Cafeterias
- Petrol station
- Convenience stores
- Quick service restaurants
- Healthcare
- Hotel room service
- Stadiums / Theaters
- Kiosk
- Food trucks

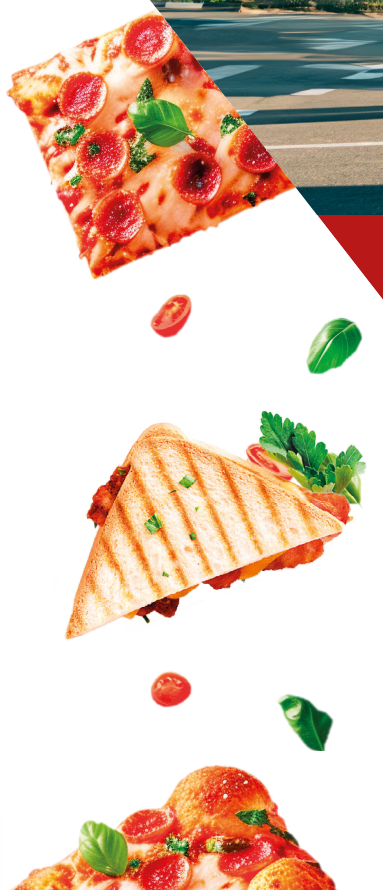

FEATURES & BENEFITS

- **FAST COOKING TIME RESULTS:** Frozen pizza 30 cm in 2 minutes.
- **SPACIOUS INTERIOR SPACE:** Up to 4 sandwiches per time.
- **SAFETY “COOL DOOR” WITH LED LIGHT:** With double glass, remains always safe and touchable and allows you to see the product inside the chamber thanks to LED light.
- **SPACE-SAVING:** Effective compact design.
- **MULTI-LANGUAGE:** Multi-language operation display.
- **EASY CLEAN SYSTEM:** Maintenance is made easy by the rounded edges of the internal cooking chamber. The SPRIZ includes a residue collecting tray.
- **HOLDING TEMPERATURE SELECTOR:** To maintain the temperature of the cooking chamber always ready to operate.
 - **CONSISTENT RESULTS & QUALITY** in every cooking process!

COOKING TECHNOLOGIES:

- **CONVECTION COOKING:** 5 fan speed.
- **IMPINGEMENT TECHNOLOGY:** Improves toasting and browning.
- **DIGITAL 2,4 LCD CONTROL:** Color LCD 2,4” screen with 100 programs and 6 fast selection programs.
- **WEB SERVER:** Easily connect to smartphones and tablets to access the menu recipe book.
- **USB PORT:** Upload/download menu items easily.
- **WI-FI / CLOUD:** The connection with the Cloud allows both remote assistance and maintenance. Add menu items to every location within a matter of minutes.

**EASY, USER FRIENDLY
AND CONNECTABLE**

*Pre-cooked
Frozen pizza*



2'
1 PC

*Chicken
Wraps*



3'
2 PCS

*Ham and cheese
Toast sandwich*



90''
4 PCS

Nachos



35''
300 GR

DIGITAL 2,4" LCD CONTROL PANEL

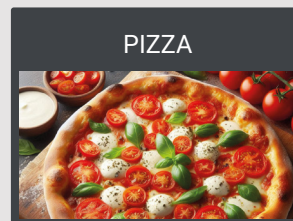
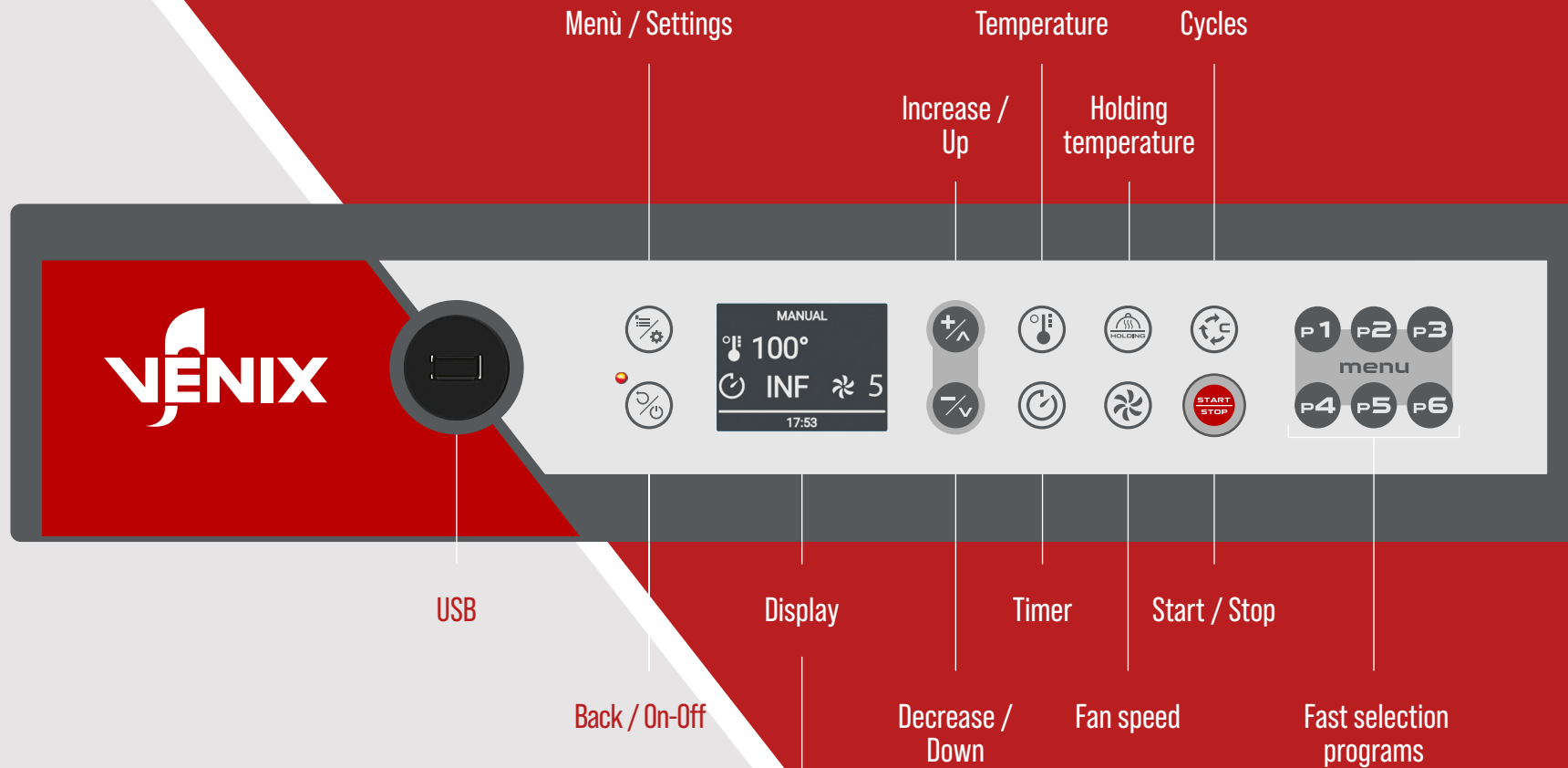

SPZLROFEROO



SPZLROGEROO



**PIZZA KIT
INCLUDED**

**PANINI KIT
INCLUDED**

**FULL KIT
INCLUDED**



SPZLROHEROO

STANDARD SPRIZ LINE



BLACK SPRIZ LINE

SPZLROHEROO BLACK



FULL KIT INCLUDED

PIZZA KIT INCLUDED

PANINI KIT INCLUDED



SPZLROFEROO BLACK



SPZLROGEROO BLACK

SPZFLA



PIZZA PADDLE
300x300mm

GPP00088



NO-STICK COOK PLATE LINERS
305x305mm

GPP00087



SOLID NO-STICK BASKET
305x305mm

GRI000327



PIZZA TEFLON TRAY
310x310mm

PIZZA KIT

ACCESSORIES



SPZSH0



PANINI PADDLE
275x316mm

GPP00086



NO-STICK COOK PLATE LINERS
270x270mm

GRI00310



PANINI GRILL
300x300mm

SPZFLA



PIZZA PADDLE
300x300mm

GPP00088



NO-STICK COOK PLATE LINERS
305x305mm

GPP00087



SOLID NO-STICK BASKET
305x305mm

GRI000327



PIZZA TEFLON TRAY
310x310mm

SPZSHO



PANINI PADDLE
275x316mm

GPP00086



NO-STICK COOK PLATE LINERS
270x270mm

GRI00310



PANINI GRILL
300x300mm

FULL KIT



ELECTRICAL DATA

Power supply	Single phase
Voltage	220-240V ~
Frequency	50/60Hz

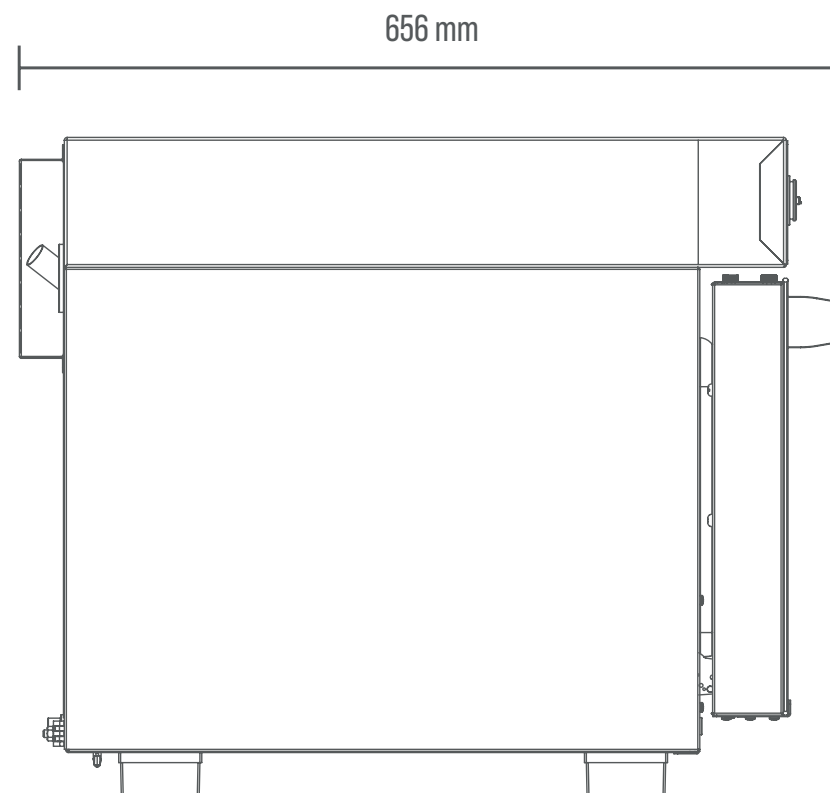
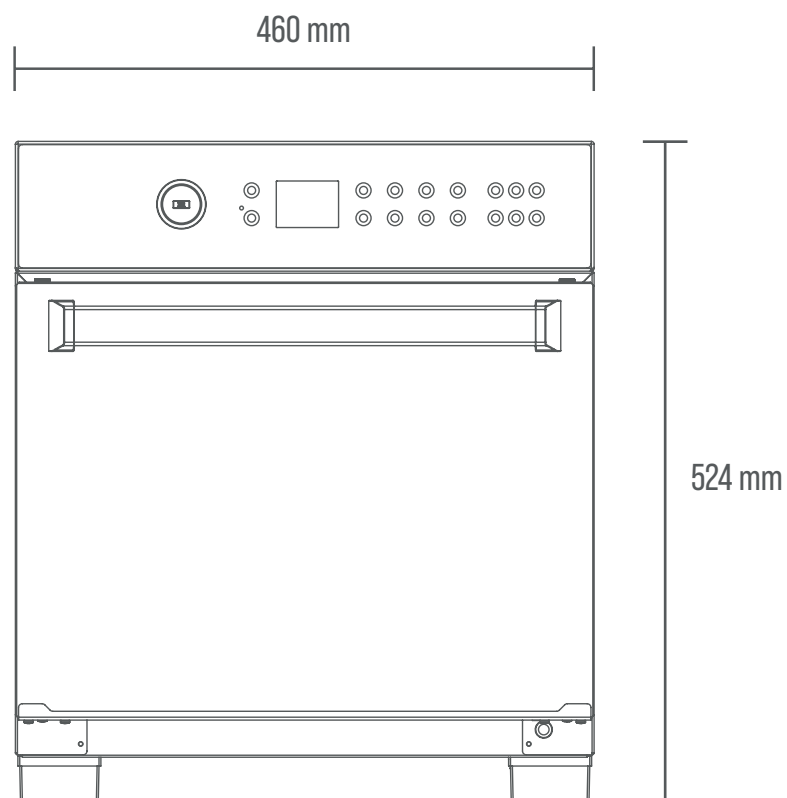

DIMENSIONAL DRAWINGS



venix.it

